

# LV 508x508

## 1. STEEL DOOR LOUVER

Type	SELF-ATTACHING & VANDAL-PROOF & NON-VISION Design;
Material	Galvanized Steel Plate

- ① Main LOUVER: (To Corridor Side)
- 1) Front Frame : 1.2mm thk., Mitered & Welded; Free of fasteners
  - 2) Blades Holder : 1.2mm thk., Full Welded Sq. / Rectangle Skeleton;  
To hold Blades and Spot-Weld Onto The Front Frame as ONE;
  - 3) Blades : 0.75mm thk.; Inverted Y shape; 11 pcs; 1" spacing
- ② Auxiliary FRAME: (Non-Corridor Side)
- 1.2mm thk., Mitered & Welded; w/ Countingsunk Screw-Holes

LOUVER O.D.	531*531mm
Free Air Flow	50% Free Area
Door Cutout	508*508mm (ORDER SIZE)
Door Thk.	45mm (Available) 50mm & 55mm (Standard)
Screws	Sheet Metal Screws; Stainless Steel; M4*30mm (Std.) 12 pcs
2. INSTALLATION	Screws fasten the auxiliary frame to the louver core thru the door cutout;

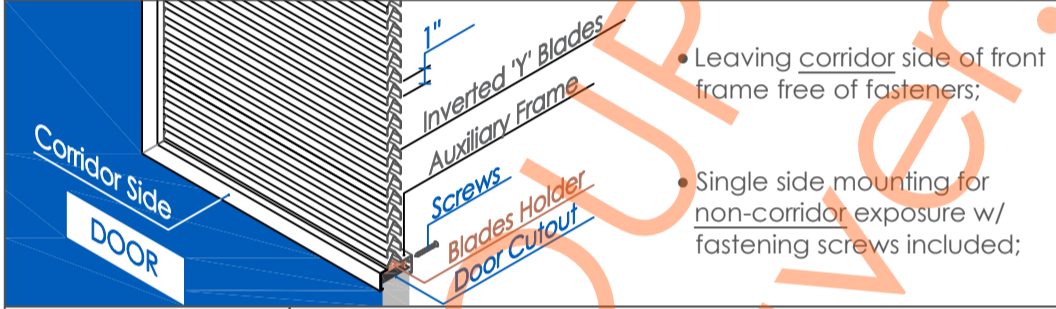

3. APPLICATION Louvered doors help ventilating room when closed while still providing privacy and security

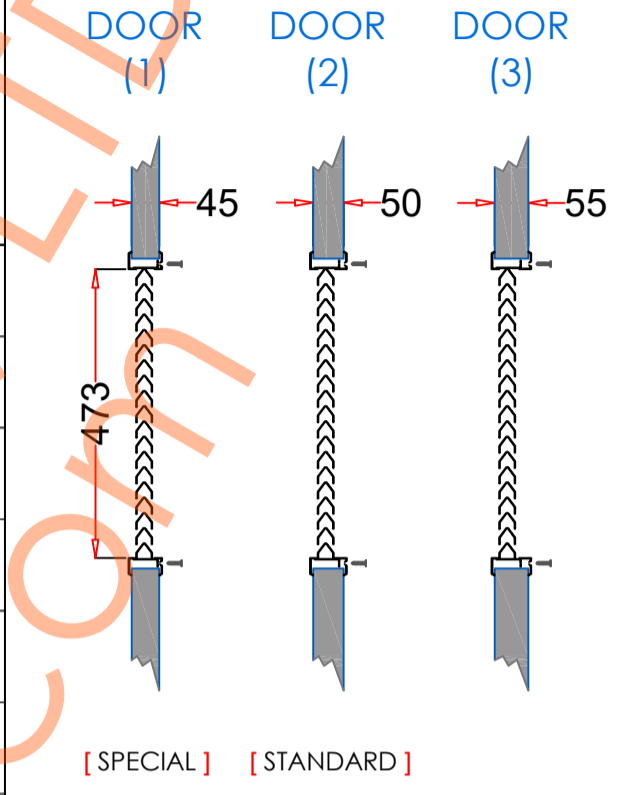

## Door & LOUVER

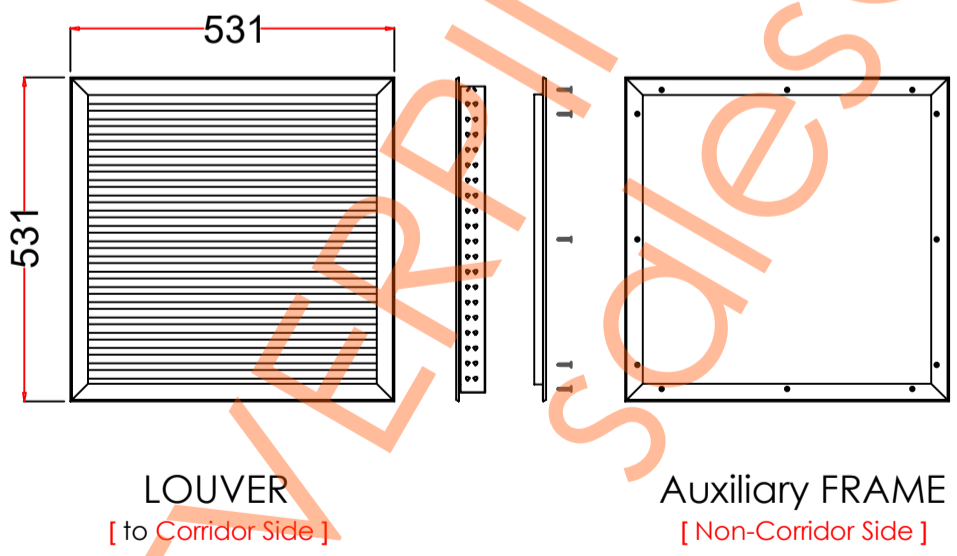

LOUVER Drawing



Door CUTOUT